



Maxam 24

Maxam 24 is a mobile, tiered seating unit that provides a simple to use, flexible seating system perfect for use in school halls and sports centres. The product can be set alongside installations of Maxam bleacher seating or used as a standalone item in a variety of layouts. The seating units are easy to deploy and can be efficiently moved to storage locations via integrated casters.

APPLICATIONS

Maxam 24 is suitable for a wide range of seating applications including: Schools, Sport Halls, Team Benches and Swimming Pools.

FEATURES

- Rolls away for efficient storage
- Simple to use and maintain
- Features the Courtside polymer bench seat



SPECIFICATIONS

- 24 seats – HSM 24 and 18 seats – HSM 24A
- Row Rise 245mm
- Row Depth 660mm
- Aisle 914mm (HSM 24A only)
- Width 2740mm
- Stored Depth 1165mm
- Stored Height 2360mm

ACCESSORIES

- Side safety rails
- Intermediate steps - For HSM24A
- Hot dipped galvanised finish for wet applications

FINISHES

- Seats: Courtside - 15 standard colours
- Metalwork: Satin Black EPC
- Beams: Galvanised
- Decks: Grey polydeck

TECHNICAL

For all technical details, please see the reverse side of this specification sheet. CAD drawings available on request.

1 2 3 4 5 6 7 8 9 10 11 12 13 14 15 16

MAXAM 24 - ROLL-AWAY

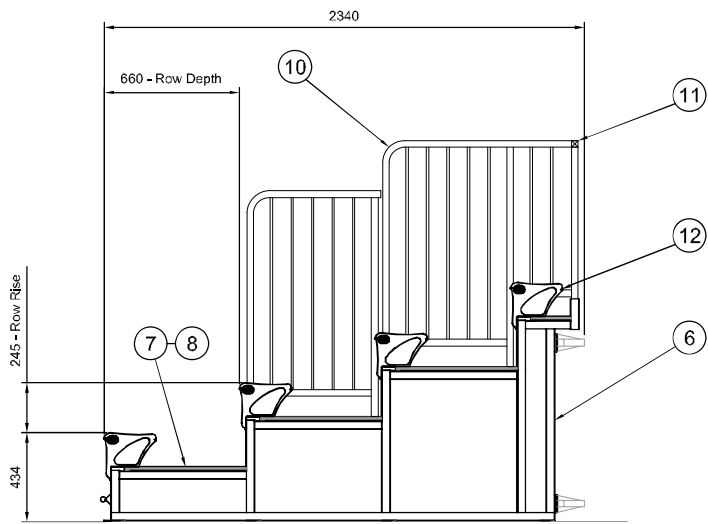

SIDE ELEVATION - Maxam 24 (HSM24)

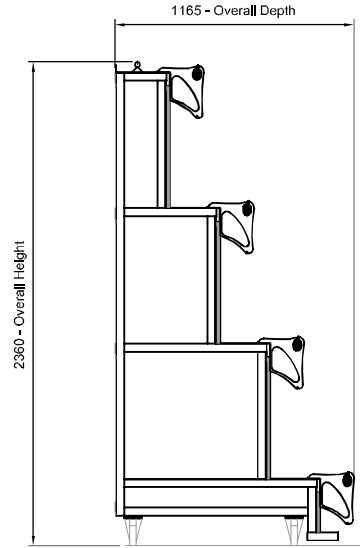

SIDE ELEVATION
(Unit in Store Position)

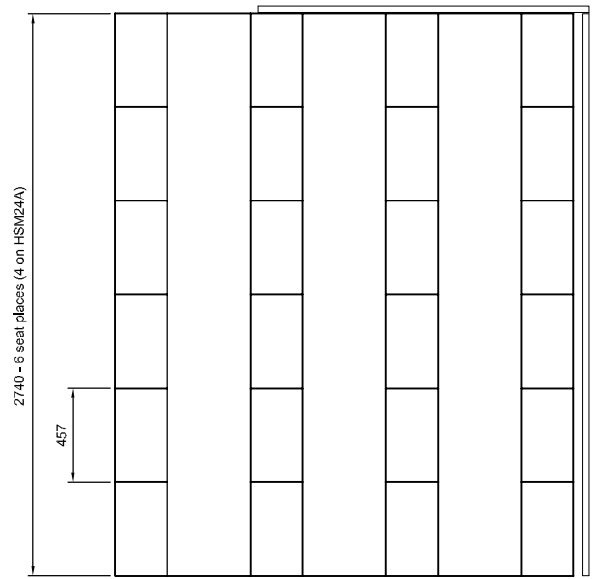

PLAN VIEW

SALES SPECIFICATION	
Ref.	Description
1	PRODUCT IDENTIFICATION: HSM24 = 24 seats HSM24A = 18 seats c/w centre aisle.
2	ROW RISE: 245 mm.
3	ROW DEPTH: 660 mm.
4	NUMBER OF ROWS: 4 No.
5	REAR PLATFORM: None.
6	PLATFORM STRUCTURE: SATIN BLACK STANDARD.
7	PLATFORM DECKING: 18 mm THICKNESS.
8	DECKING FINISH: Grey PVC (Polydeck)
9	INTERMEDIATE STEPS: 3 no. on HSM24A
10	SIDE RAILS: ACCESSORY - Specify number required.
11	REAR RAILS: INCLUDED (Standard Equipment)
12	SEAT TYPE: Maxam COURTSIDE
13	SEAT CENTRES: 457 mm, nominal
TOTAL SEAT QUANTITY: HSM24 = 24 seats HSM24A = 18 seats	

RevNo	Revision note	Date	Signature	Checked
B				

GENERAL TOLERANCE ± 1.0 mm



THIS DRAWING IS THE PROPERTY AND COPYRIGHT OF HUSSEY SEATWAY LTD. COPYING OR REPRODUCTION WITHOUT WRITTEN PERMISSION IS PROHIBITED. © 2003
Tel: +44 (0)1985 847200
Fax: +44 (0)1985 847300
Email: info@husseyseatway.com

Item#	Quantity	Unit	Name, designation, material, dimension etc.	Article No./Reference
-------	----------	------	---	-----------------------

SALES DRAWING						
MAXAM 24 Roll-away Seating Unit.			Date: 19/06/06	Drawn by: SWB	Checked by: XXX	A1 Scale: 1:12
			M24 - 1001	Revision: A	Sheet: 1/1	

1 2 3 4 5 6 7 8 9 10 11 12 13 14 15 16